

SEC 5000 *IRE*volution Gas Detector

Instruction and Operation Manual

Sensor Electronics Corporation
12730 Creek View Avenue
Savage, Minnesota 55378 USA
(952) 938-9486 Fax (952) 938-9617
Email: sales@sensorelectronics.com
Web site: www.sensorelectronics.com

Sensor Electronics Corporation

Sensor Electronics Corporation (SEC) designs and manufactures innovative fixed system gas detection equipment, for combustible gases, oxygen, carbon dioxide and toxic gases.

Commitment

Our quality and service are uncompromising. We back each of our products with a two-year warranty on all materials and workmanship. We offer technical support, user training and on-site service and maintenance of equipment to meet the needs of our customers.

Gas Detection Service

Individually designed maintenance packages are available for specific customer needs. Service begins with verification of the system installation that includes an initial system check and calibration. We then offer customer training programs (on-site and at factory) to insure that technical personnel fully understand operation and maintenance procedures. When on-the-spot assistance is required, service representatives are available to handle any questions or problems immediately.

Warranty

Sensor Electronics Corporation (SEC) warrants products manufactured by SEC to be free from defects in workmanship and materials for a period of two (2) years from date of shipment from the factory. Any parts returned freight pre-paid to the factory and found defective within the warranty would be repaired or replaced, at SEC's option. SEC will return repaired or replaced equipment pre-paid lowest cost freight. This warranty does not apply to items, which by their nature are subject to deterioration or consumption in normal service. Such items may include:

Fuses and Batteries.

Warranty is voided by abuse including rough handling, mechanical damage, alteration or repair. This warranty covers the full extent of SEC liability and SEC is not responsible for removal, replacement costs, local repair costs, transportation costs or contingent expenses incurred without prior written approval. Sensor Electronics Corporation's obligation under this warranty shall be limited to repair or replacement of any product that has been returned to Sensor Electronics Corporation for warranty consideration. This warranty is expressly in lieu of any and all other warranties expressed or implied, and all other obligations or liabilities on the part of Sensor Electronics Corporation including but not limited to, the fitness for a particular purpose. In no event shall Sensor Electronics Corporation be liable for direct, incidental, or consequential loss or damage of any kind connected with the use of its products or failure to function or operate properly.

CONVENTIONS

The following conventions are used in this manual.



Warning Statement



VDC (DC Voltage)

Revision History

Rev	ECO#	DATE	Description of Change	Page
A	000231	6/20/2017	Initial Release	All
B	000294	10/6/2020	Add Reflector Versions to Approval Add Page Numbers Add Figures 5 and 6 Add thread Lubrication Recommendation	5 All 9
C	00340	06/20/2023	Add Specific Condition of Use from IECEx Approval Certificate	10

Table of Contents

- I. SPECIFICATIONS
- II. GENERAL DESCRIPTION
- III. OPERATION
 Installation and Startup
- IV. CALIBRATION
- V. MAINTENANCE
- VI. PARTS LIST
- VII. DRAWING SECTION

I. SPECIFICATIONS

Model Numbers:

Sensor Electronics Corporation SEC 5000 /REvolution Infrared Gas Detector

Model Number	Description
5001	Evolution Family, Stainless Steel, Short Enclosure, Germanium Windows
5101	Evolution Family, Aluminum, Short Enclosure, Germanium Windows
5200	Evolution Family, Long Source (XS)/Aluminum, Short Enclosure, Sapphire Windows
5201	Evolution Family, Long Source (XS)/Aluminum, Short Enclosure, Germanium Windows
5210	Evolution Family, Long Source (XS)/Aluminum, Long Enclosure, Sapphire Windows
5211	Evolution Family, Long Source (XS)/Aluminum, Long Enclosure, Germanium Windows
5300	Evolution Family, Long Source (XS)/Stainless Steel, Short Enclosure, Sapphire Windows
5301	Evolution Family, Long Source (XS)/Stainless Steel, Short Enclosure, Germanium Windows
5310	Evolution Family, Long Source (XS)/Stainless Steel, Long Enclosure, Sapphire Windows
5311	Evolution Family, Long Source (XS)/Stainless Steel, Long Enclosure, Germanium Windows
5400	Evolution Family, Aluminum, Short Enclosure, Sapphire Windows
5550	Evolution Family, Stainless Steel, Short Enclosure, Sapphire Windows
5600	Evolution Family, Long Source (XS)/Aluminum/Reflector Block, Short Enclosure, Sapphire Windows
5601	Evolution Family, Long Source (XS)/Aluminum/Reflector Block, Short Enclosure, Germanium Windows
5610	Evolution Family, Long Source (XS)/Aluminum/Reflector Block, Long Enclosure, Sapphire Windows
5611	Evolution Family, Long Source (XS)/Aluminum/Reflector Block, Long Enclosure, Germanium Windows
5700	Evolution Family, Long Source (XS)/Stainless Steel /Reflector Block, Short Enclosure, Sapphire Windows
5701	Evolution Family, Long Source (XS)/Stainless Steel/Reflector Block, Short Enclosure, Germanium Windows
5710	Evolution Family, Long Source (XS)/Stainless Steel/Reflector Block, Long Enclosure, Sapphire Windows
5711	Evolution Family, Long Source (XS)/Stainless Steel/Reflector Block, Long Enclosure, Germanium Windows

Available gases:

Methane
 Hexafluoro Butadiene
 Difluoromethane
 Methyl Fluoride
 Ammonia

Please note that this list is not all-inclusive. The SEC 5000 IREvolution can be calibrated for many other gases, provided a calibration gas is available. For more please contact Sensor Electronics Corporation.

Detection Method:

Diffusion

Output (analog):

4-20 mA (Source type), max. 1000 Ohm load at 24 VDC supply voltage

Response Time (Methane Version):

T50 < 15 seconds
 T90 < 30 seconds

Construction:

316 stainless steel (SEC 5000)
 6061 Aluminum (SEC 5100)

Dimensions: Length x Diameter

Stainless	5.5in x 2.5in
Stainless (Long)	11.59 x 2.5in
Aluminum	5.75in x 2.75in
Aluminum (Long)	11.6in x 2.75in

Unit Weight (Approximate):

Stainless Steel	3.7 lb
Stainless Steel (Long)	5.8 lb
Aluminum	1.9 lb
Aluminum (Long)	3.0 lb

Accuracy (Methane Version):

+/- 3% of Full Scale for applied gas concentrations up to 50% of full scale
 +/- 5% of Full Scale for applied gas concentrations above 50% of full scale

Operating Temperature Rating:

-40° to +50°C at 0 to 99% RH (non-condensing)

Operating Voltage:

24 VDC $\overline{=}$ Operating range: 18 to 32 VDC measured at the detector head

Power Consumption: 5.1 Watts Max.

Max. Current Draw: (at 24 VDC)

Average: 210 mA (Peak: 400 mA)

Approvals: APPROVED MODELS ONLY:

5001/5101/5200/5201/5210/5211/5300/5301/5310/5311/5400/5500
 IECEx ITS 17.0055X: Ex db op is IIB T5 Gb

Installation Category: Cat. I, Pollution Degree 2

II GENERAL DESCRIPTION

The SEC 5000 *IREvolution* Infrared gas detector is a rugged reliable microprocessor based intelligent gas detector. The SEC 5000 can be used to monitor for explosive Hydrocarbons, Alcohols, PFCs, Ammonia and many others.

The SEC 5000 *IREvolution* is ideally suited for use in harsh environments and where the costs of required maintenance for conventional catalytic or electrochemical detectors are prohibitive. The SEC 5000 *IREvolution* Infrared gas detector will perform reliably in the presence of silicone and other catalytic poisoning agents and can also operate in oxygen free environments or where high background gas levels are present. There are no known poisons that affect this technology.

The SEC 5000 *IREvolution* is a stand-alone device providing a linear continuous 4 to 20 mA output representing 0 to Full Scale.

Features

- Requires no routine calibration to ensure proper operation.
- Continuous self-test automatically indicates a fault, with fail to safe operation.
- A multi-layered filtering system protects optics from dirt and water ingress.
- Straight optical path eliminates the need for reflective surfaces, such as mirrors or beam splitters.
- Performs well in the presence of high concentrations or constant background levels of hydrocarbons and in oxygen depleted atmospheres.
- Highly resistant to poisoning and etching.
- Standard 4 to 20 mA output (current source)
- Explosion proof housing designed for harsh environments.
- Smart Calibration AutoAC™ circuit.

Infrared Detection Technology

The SEC 5000 *IREvolution* Infrared gas detector uses infrared absorption technology for detecting combustible hydrocarbon gases. Gases absorb infrared light only at certain wavelengths. The concentration of a gas can be quantified by measuring and comparing intensities in light bands where there is significant absorption by the target gas and in bands where there is little absorption by the target gas. The SEC 5000 *IREvolution* uses an infrared light source that passes collimated light through a waveguide containing the gas sample. At the other end of the waveguide is a multiple channel receiver. The measuring channel intensities and the reference channel intensities are then analyzed to quantify the gas concentration. The gas concentration is then represented at the output as a gas density measurement or a %Vol measurement/PPM measurement (selectable).

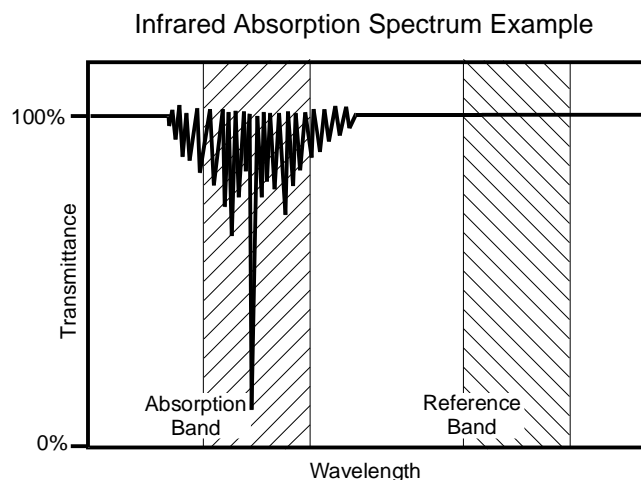

The multiple-channel receiver consists of several filtered light sensors monitoring light bands critical to the target gas. The multi-channel design affords high sensitivity, high selectivity, excellent drift control and superior thermal stability over the entire temperature range.

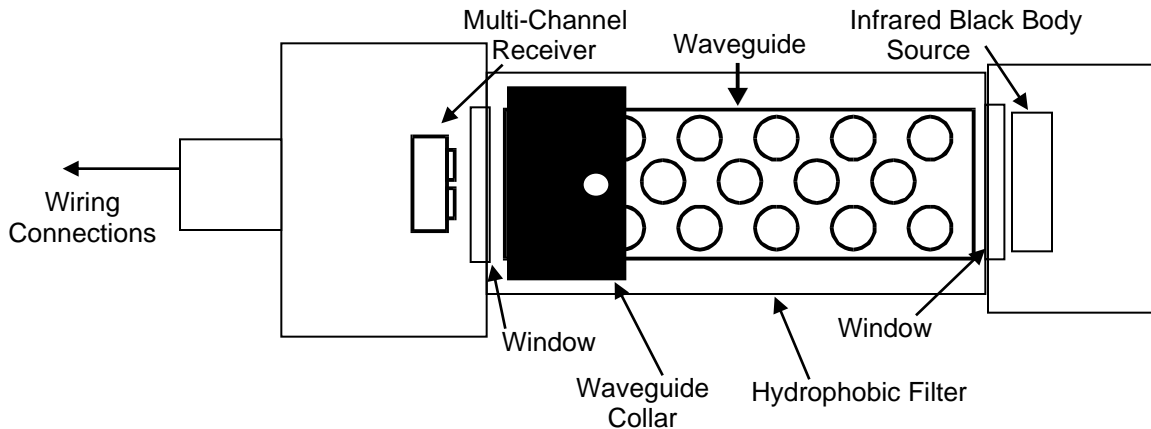

The straight line optical system eliminates the need for any special lenses or beam splitters.

The SEC 5000 *IREvolution* utilizes a unique patent pending feature, the AutoAC™ circuit. The AutoAC™ circuit is an automatic analog control circuit, which allows the SEC 5000 *IREvolution* to be calibrated for any combustible hydrocarbon, provided that a calibration quality level of the gas is available. This eliminates setting dipswitches or changing out sensors for different types of hydrocarbons; simply calibrate the unit with a calibration gas of the specific gas to be detected.

The optics can be easily disassembled for cleaning. This does not require powering the unit down and does not compromise the units' explosion proof rating. The device will self-compensate for dirty optics until a point at which the optical surfaces are completely obscured.

There are no consumable components contained in this product.

III. OPERATION

Installation and Startup

 Warning: The user shall be made aware that if the equipment is used in a manner not specified by the manufacturer, the protection provided by the equipment may be impaired.

The first step in the installation process is to establish a mounting location for the SEC 5000 *IREvolution*. Select a location that is typical of the atmosphere to be monitored or close to the anticipated source of a dangerous gas.

It is very important that the SEC 5000 *IREvolution* be properly located to enable it to provide maximum protection. The most effective number and placement of sensors vary depending on the conditions of the application. When determining where to locate sensors the following factors should be considered.

- What are the characteristics of the gas that is to be detected? Is it lighter or heavier than air? If it is lighter than air the sensor should be placed above the potential gas leak. Place the sensor close to the floor for gases that are heavier than air or for vapors resulting from flammable liquid spills. Note that air currents can cause a gas that is heavier than air to rise. In addition, if the temperature of the gas is hotter than ambient air or mixed with gases that are lighter than air, it could also rise.
- How rapidly will the gas diffuse into the ambient air? Select a location for the sensor that is close to the anticipated source of a gas leak.
- Wind or ventilation characteristics of the immediate area must also be considered. Movement of air may cause gas to accumulate more heavily in one area than in another. The detector should be placed in the areas where the most concentrated accumulation of gas is anticipated. For outdoor applications with strong wind conditions, it may require the sensors to be mounted closer together and on the down wind side, to the anticipated area of a gas leak. Also take into consideration for indoor applications, the fact that many ventilation systems do not operate continuously.
- The sensor should be accessible for maintenance.
- Excessive heat or vibration can cause premature failure of any electronic device and should be avoided if possible.
- Follow all national and local installation codes and practices.

The SEC 5000 *IREvolution* has a $\frac{3}{4}$ " NPT threaded connector for mounting the detector to a certified explosion proof junction box. It is recommended to put some sort of thread lubrication on the NPT threads so that if the sensor ever needs to be removed, the threads won't be damaged. The thread engagement shall be at least 5 full threads. Corrosion inhibiting grease may be used if it is non-setting and if earthing/grounding between the certified metallic junction box and detector is maintained.

The bonding connection on the cap of the detector must provide an effective connection for earthing/grounding. This is done by using a conductor of at least 4 mm². It is acceptable to use suitable wiring lugs for installation if necessary.

SEC can provide a junction box with terminals for this purpose. A conduit seal must be installed within 18" of the detector for use of approved units.

A user-supplied junction box can be used providing it has the appropriately sized NPT conduit entries. The junction box and terminal blocks must be suitable for use in the application and location in which it is being

installed. After the device has been installed, a calibration is required. Refer to the Calibration section of this manual.

Note: The SEC 5000 IREvolution cannot be used as a seal for a flame-proof enclosure.

Specific Conditions of Use:

Per the IECEx approval for the SEC5000 product line:

- i. The integral conductors shall be suitably mechanically protected and terminated in a suitable terminal or junction facility, and the junction facility cannot generate a pressure greater than 824 PSI (56.8 bar).
- ii. It is the user's responsibility to ensure that the earth continuity of the equipment is maintained via the mounting arrangement.
- iii. The equipment flameproof joints are not intended to be repaired.

Wiring connections

Red wire: 18 to 32 VDC 

Black wire: DC Common

Blue wire: 4 to 20 mA output

White wire: Smart Calibration Wire (data wire)

Earth Ground: 10-32 Green Ground Screw on IREvolution cap, see figure 1.

Wire sizing:

0 to 500 feet, recommended wire gauge size 16 AWG (rated at least 8°C above max. ambient)

501 to 1000 feet, recommended wire gauge size 14 AWG (rated at least 8°C above max. ambient)

Shielded cable is recommended. Wiring should be installed in metal conduit with no other cabling in the same conduit.

Warm-up

When power is applied to the detector, it enters a one (1) minute warm-up mode. The output current will be 4.0 mA during the warm up time period. At the end of the warm-up period with no faults present, the detector automatically enters the normal operating mode (4-20mA). If a fault is present after warm-up, the detector current output will indicate a fault. See the following chart for fault code status.

Normal Operation

In the normal operating mode, the 4 to 20 mA signal levels correspond to the detected gas concentration. The detector continuously checks for system faults or initiation of calibration and automatically changes to the appropriate mode.

The 4 to 20 mA output of the SEC 5000 IREvolution is a non-isolated current source.

Current Output and Corresponding Status

<u>Current Output</u>	<u>Status.</u>
0.6 mA	Unit Fault
4.0 mA	Unit warm up
1.0 mA	Optics fault
1.2 mA	Zero drift fault
1.6 mA	Calibration fault
2.0 mA	Unit spanning
2.2 mA	Unit zeroing
2.4 mA	Reference Channel Fault
2.6 mA	Analytical Channel Fault
4.0 mA	Zero gas level (0% F.S.)
5.6 mA	(10% Full Scale)
8.0 mA	(25% Full Scale)
12 mA	(50% Full Scale)
16 mA	(75% Full Scale)
20 mA	Full scale (100% F.S.)
>20 mA	Over-range (> 100% F.S.)

CAUTION: HIGH OFF-SCALE READINGS
(READINGS GREATER THAN 20mA) MAY
INDICATE AN EXPLOSIVE CONCENTRATION

Once the fault is cleared the SEC 5000 /REvolution will automatically resume normal operation.

IV. CALIBRATION

The SEC 5000 *IREvolution* is factory calibrated zeroed and spanned. *Unlike catalytic sensors it does not require routine span gas calibration to ensure proper operation.*

A typical field calibration only requires the use of zero air (or 99.99% nitrogen). *If the sensor is located in an area that is known to be free of the target gases then ambient air can be used as a zero reference.*

If zero air is used for the calibration, there is a fitting at the side of the sensor for a 1/8" ID tubing connection.

Zero Calibration

Before beginning calibration use the SEC 5000 *IREvolution* Insulation Tube to cover outer cylinder holes and connect a clean air source to the sensor's calibration port for a minimum of 3 minutes. To enter into the calibration mode, the calibration (white) wire must be connected to the DC Common (black) wire for ten (10) seconds, upon release the sensor will automatically enter the zero calibration routine. The electronics will automatically adjust the sensor's signal to the new zero reference level. During the zero calibration routine, the current output of the SEC *IREvolution* will go to 2.2 mA. Although this can be accomplished manually, installation of a switch (contact closure) can accomplish the zeroing procedure. It is recommended that this switch be a momentary type switch to prevent it from inadvertently being left in the calibrate position. If after 20 seconds the calibration lead has not been removed from common, the SEC 5000 *IREvolution* will ignore the signal and continue operation as normal. If the SEC5000 is connected to an SEC transmitter, the Zero operation can also be initiated by the transmitter from the Calibration menu. The calibration wire initiation is only used if no transmitter is connected.

Span Calibration

The SEC *IREvolution* can also be spanned in the field. Initiating the Spanning operation is similar to initiating the Zeroing operation other than the calibration wire is connected to the +24V (red) wire for 10 seconds and released. The Span initiation command is also available at the transmitter from the calibration menu. The output current will go to 2.0mA while the unit is spanning.

It is highly recommended that a Zero be performed prior to a Span.

The spanning concentration for the SEC5000 is always ½ of the full scale concentration.

Please contact the factory for further details.

V. MAINTENANCE

The SEC 5000 *IREvolution* does not normally require cleaning of the optics. However if the unit is operating in a very dirty or dusty environment the optical path might become obscured. If the obscuration is severe enough to affect the unit's accuracy, the unit will indicate an "Optics Fault". To clear an Optics Fault, first try a calibration. If the calibration does not correct the fault condition, clean the optics.

The outer barrel can be removed by loosening the two screws at the top of the barrel and rotating barrel slightly clockwise until barrel can be pulled free. You will then see the hydrophobic filter. The hydrophobic filter is a Teflon coated stainless steel mesh that keeps moisture and particulates out of the optical path. The top of the filter snaps into a groove in the housing and is located by a pin in the housing. Pulling the filter free of the groove allows the filter to be removed. Once the hydrophobic filter is removed, the internal waveguide tube should be inspected for cleanliness. The waveguide and waveguide collar can be removed by inserting rigid instruments such as Allen wrenches into one hole of the waveguide and one hole of the collar. Turning the collar counterclockwise with respect to the tube will loosen the waveguide allowing the collar to be screwed down on to the waveguide until it can be removed from the SEC 5000 *IREvolution* housing. This will allow access to the windows of the SEC 5000 *IREvolution* for cleaning.

Dust can be removed using compressed air. Hard or oily deposits can be removed using Isopropyl alcohol and cotton tipped swabs. Wipe any film or residue left by the alcohol on the windows with a clean dry cotton swab. The internal electro-polished wave-guide tube can be cleaned the same way. Be careful not to leave any particles of the cleaning swab in the waveguide. The waveguide holes can collect pieces of the cleaning swab.

After reassembling the unit (the waveguide and collar should be very tight to both ends of the SEC 5000 IREvolution housing. Once the unit is completely reassembled and power is reapplied, the SEC 5000 IREvolution must then be Zero calibrated. Refer to the calibration section of this manual.

If the fault doesn't clear, contact the factory.

VI. Parts List

Part Number	Description
142-2188	Replacement Hydrophobic Filter
142-2409	Wave Guide Tube
142-2408	Wave Guide Tube Collar

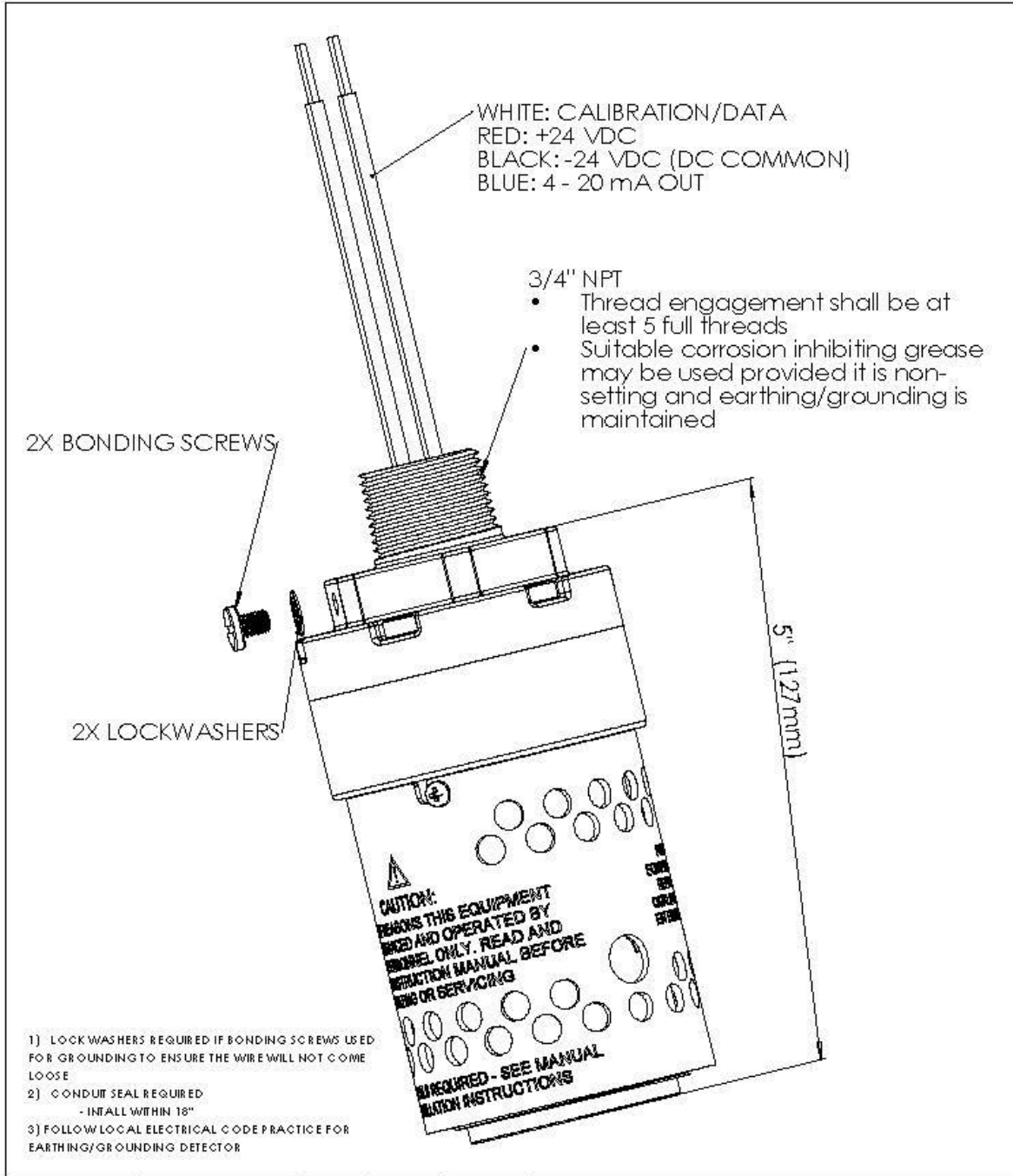

APPROVALS:		DIMENSIONS ARE IN INCHES TOLERANCES: FRACTIONAL ±		NAME	DATE	 Sensor Electronics Corp. 12730 Creek View Ave Savage, Minnesota 55378	
SCHEMATIC	N/A	ANGULAR: MAX CH ±1° BEND ± TWO PLACE DECIMAL ±0.10 THREE PLACE DECIMAL ±0.05		DRAWN	C. PETERS		02/2012
PWB RAW	N/A			CHECKED			
CERT DWG	\$100-000 EX			MFG APPR.			
CERT DWG REV	B	MARKS	PROPRIETARY AND CONFIDENTIAL THE INFORMATION CONTAINED IN THIS DRAWING IS THE SOLE PROPERTY OF SENSOR ELECTRONICS CORP. ANY REPRODUCTION IN PART OR AS A WHOLE WITHOUT THE WRITTEN PERMISSION OF SENSOR ELECTRONICS CORP. IS PROHIBITED.				SEC5000 WIRING DIAGRAM FIGURE 1
NEXT ASSY	N/A	REVISION					
USED ON	SECS100			SUB	A	DWG. NO.	
APPLICATION	DO NOT SCALE DRAWING			SCALE	1:1	REV.	

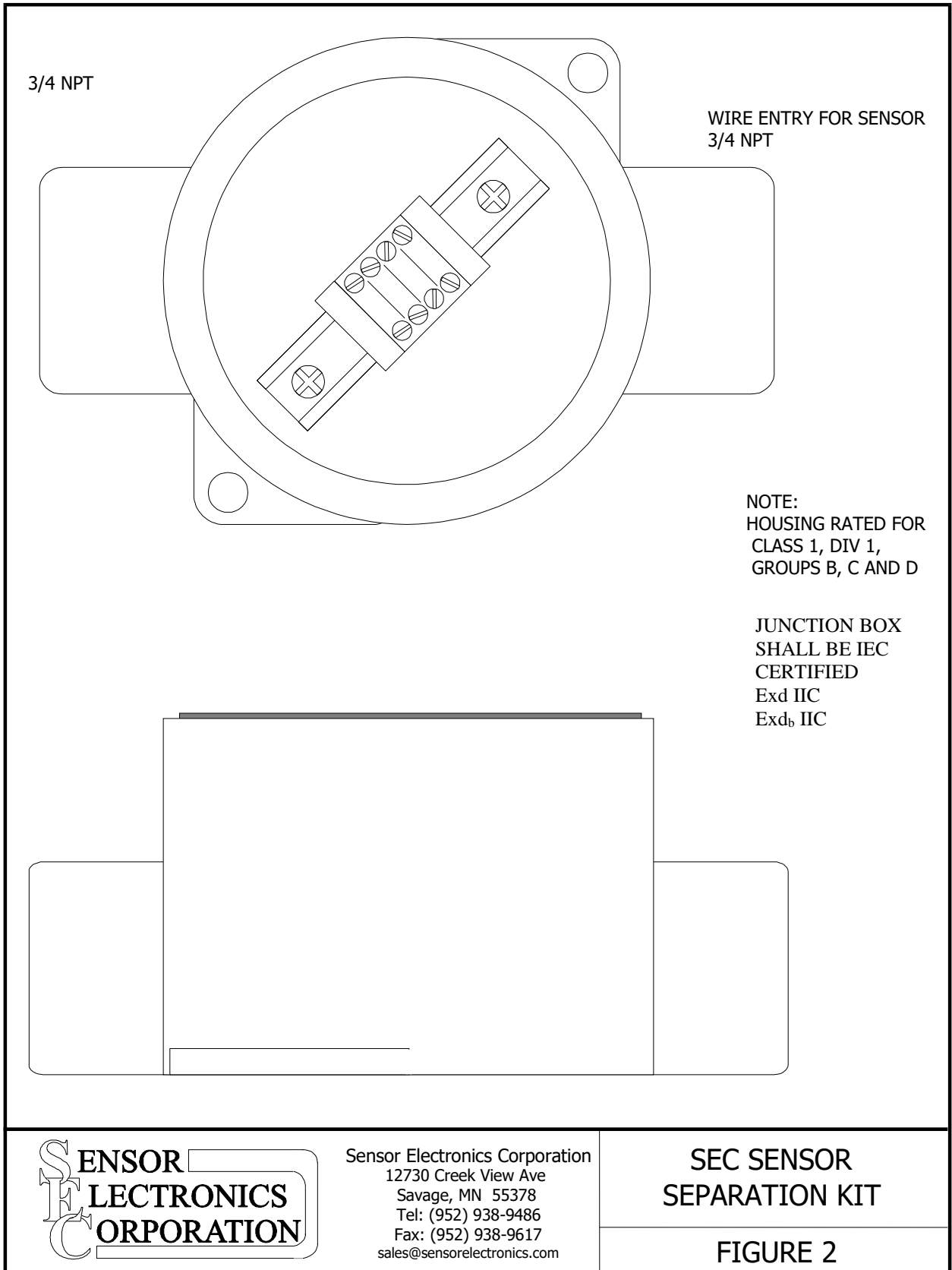

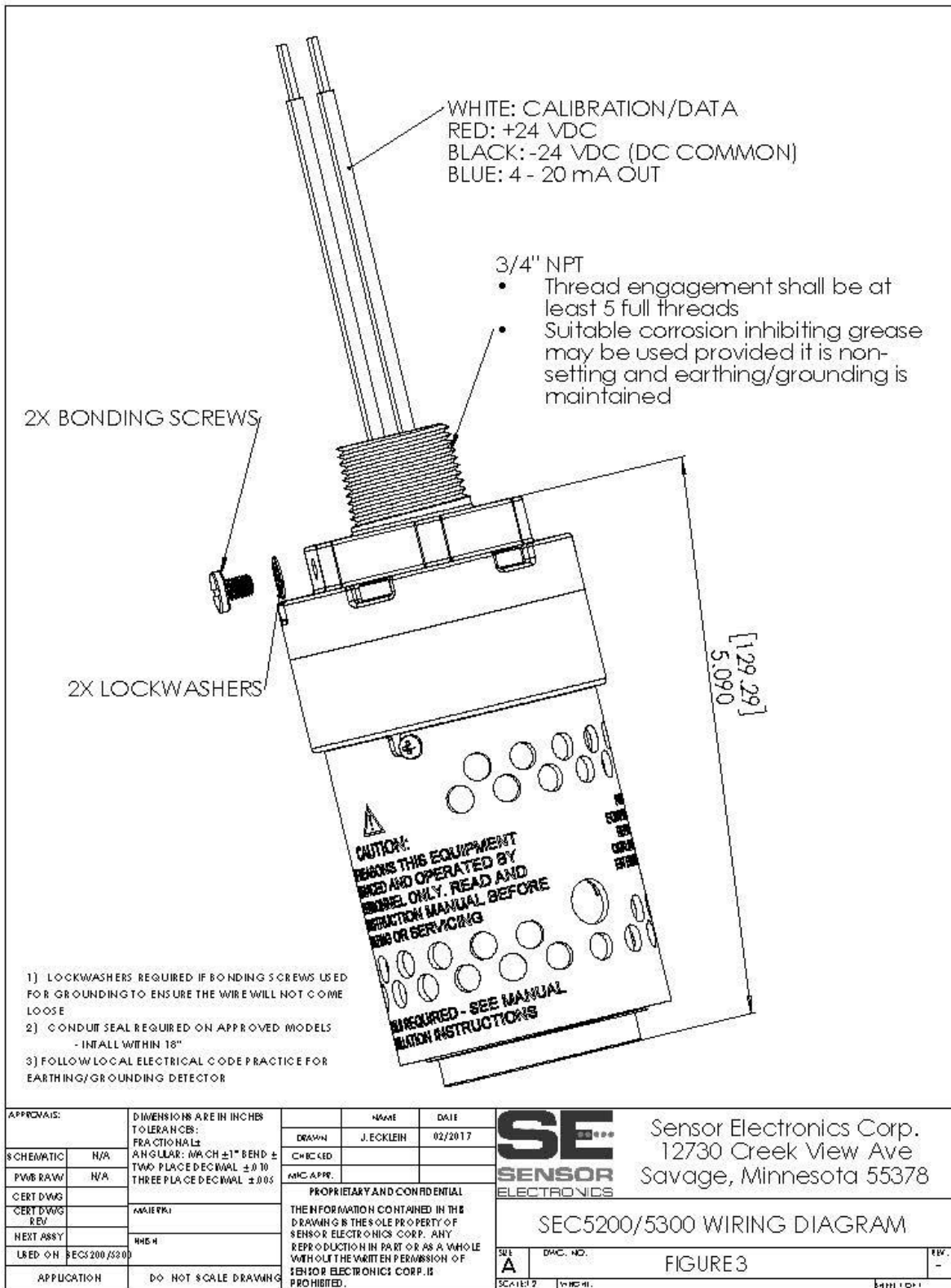

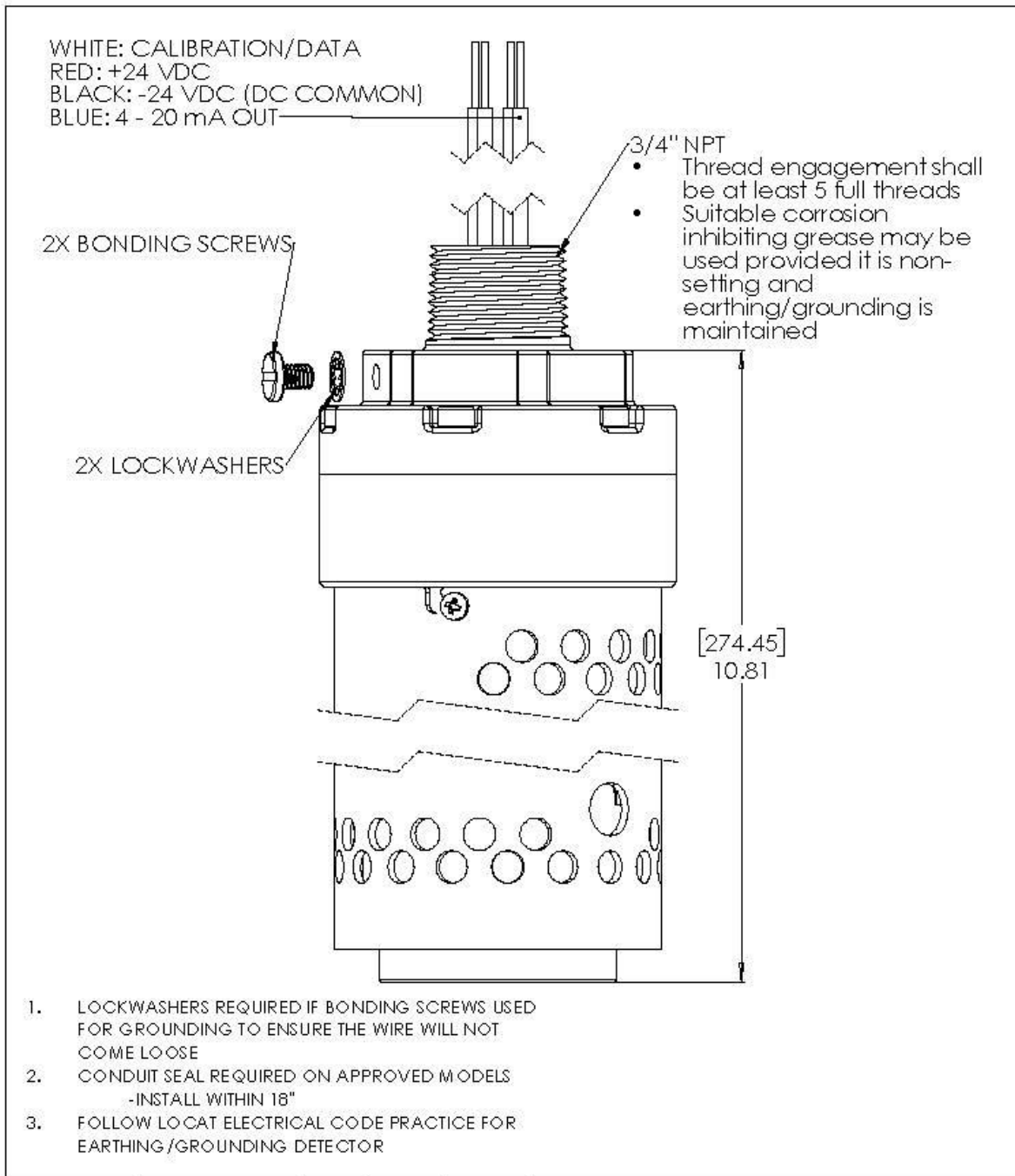

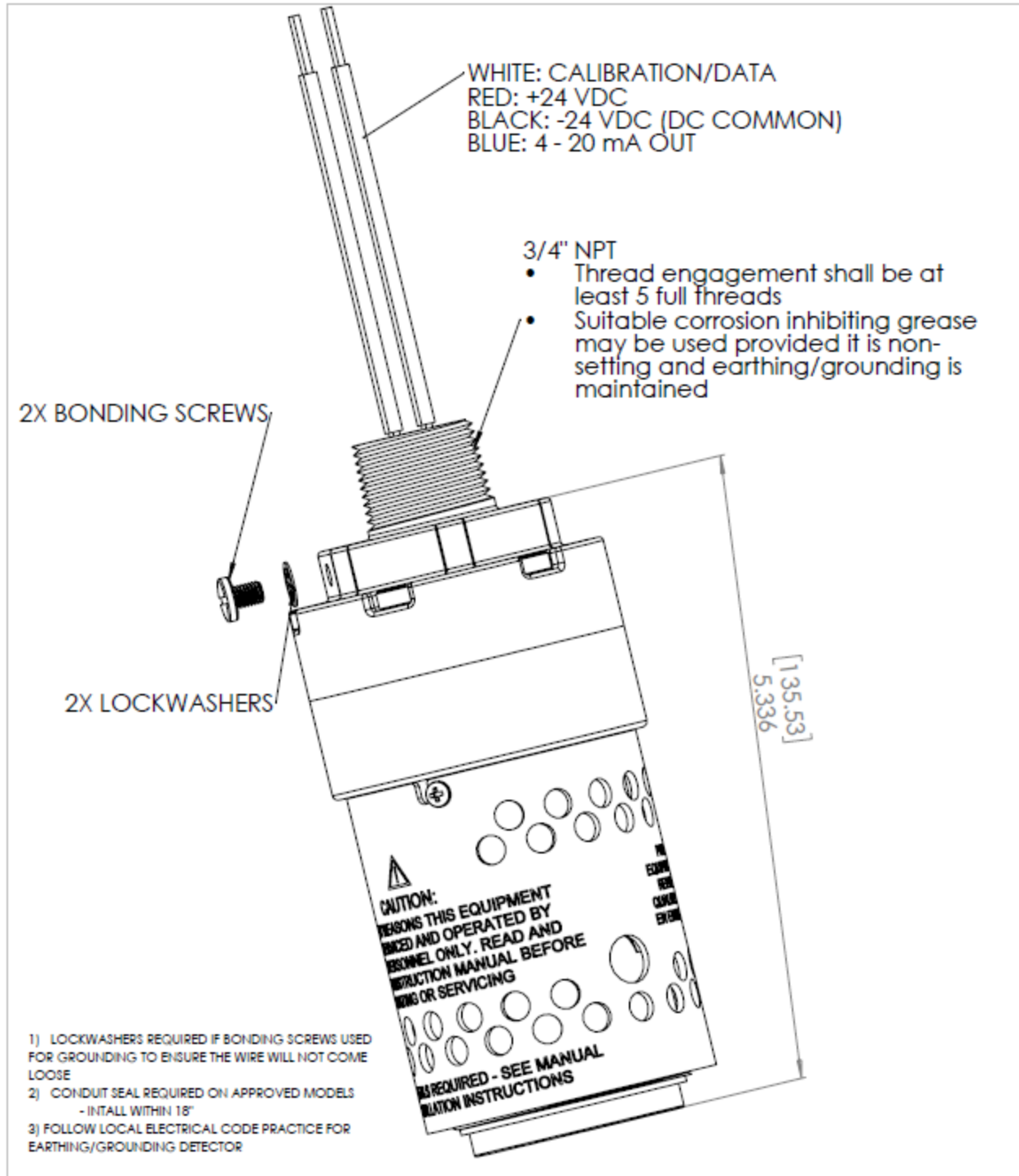

APPROVALS:		DIMENSIONS ARE IN INCHES TOLERANCES: FRACTIONAL ± ANGULAR: MAX ±1° BEND ± TWO PLACE DECIMAL ±0.10 THREE PLACE DECIMAL ±0.05		NAME	DATE	 Sensor Electronics Corp. 12730 Creek View Ave Savage, Minnesota 55378
SCHEMATIC	N/A	CHECKED	J. ECKLEH	02/2017	PROPRIETARY AND CONFIDENTIAL THE INFORMATION CONTAINED IN THIS DRAWING IS THE SOLE PROPERTY OF SENSOR ELECTRONICS CORP. ANY REPRODUCTION IN PART OR AS A WHOLE WITHOUT THE WRITTEN PERMISSION OF SENSOR ELECTRONICS CORP. IS PROHIBITED.	
PWB RAW	N/A	AMC APPR.				
CERT DWG		APPLICATION DO NOT SCALE DRAWING			SEC5210/5211/5310/5311 WIRING DIAGRAM FIGURE 4	REV. -

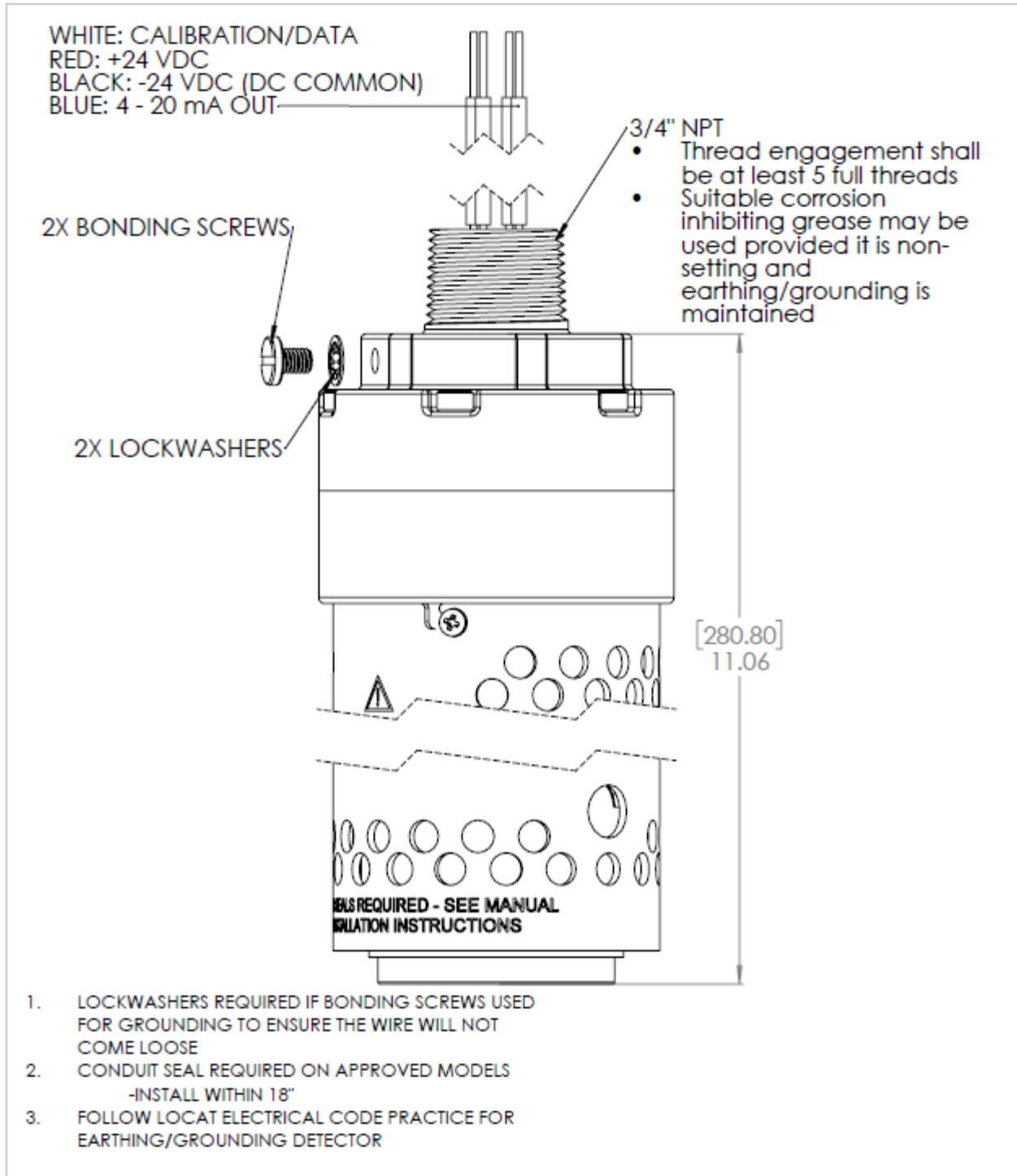

APPROVALS:		DIMENSIONS ARE IN INCHES TOLERANCES: FRACTIONAL ±		NAME	DATE	 Sensor Electronics Corp. 12730 Creek View Ave Savage, Minnesota 55378 SENSOR ELECTRONICS	
SCHEMATIC	N/A	ANGULAR: MACH ±1° BEND ±		DRAWN	J.ECKLEN		11/2020
PWB RAW	N/A	TWO PLACE DECIMAL ±.010		CHECKED			
CERT DWG		THREE PLACE DECIMAL ±.005		MFG APPL.			
CERT DWG REV.		MATERIAL		PROPRIETARY AND CONFIDENTIAL THE INFORMATION CONTAINED IN THIS DRAWING IS THE SOLE PROPERTY OF SENSOR ELECTRONICS CORP. ANY REPRODUCTION IN PART OR AS A WHOLE WITHOUT THE WRITTEN PERMISSION OF SENSOR ELECTRONICS CORP. IS PROHIBITED.			
NEXT ASSY		FINISH		SEC560X/570X WIRING DIAGRAM			
USED ON	SEC560X/570X	DO NOT SCALE DRAWING		SIZE	DWG. NO.	REV.	
APPLICATION				A	FIGURE 5	-	
				SCALE:1:2	WEIGHT:	SHEET 1 OF 1	



APPROVALS:		DIMENSIONS ARE IN INCHES TOLERANCES: FRACTIONAL ± ANGULAR: MACH ±1° BEND ± TWO PLACE DECIMAL ±.010 THREE PLACE DECIMAL ±.005		NAME	DATE	 <p>Sensor Electronics Corp. 12730 Creek View Ave Savage, Minnesota 55378</p>
SCHMATIC	N/A	DRAWN	J.ECKLEIN	11/2020		
PWB RAW	N/A	CHECKED				
CERT DWG		MFG APPR.				<p>PROPRIETARY AND CONFIDENTIAL</p> <p>THE INFORMATION CONTAINED IN THIS DRAWING IS THE SOLE PROPERTY OF SENSOR ELECTRONICS CORP. ANY REPRODUCTION IN PART OR AS A WHOLE WITHOUT THE WRITTEN PERMISSION OF SENSOR ELECTRONICS CORP. IS PROHIBITED.</p>
CERT DWG REV.		MATERIAL				
NEXT ASSY		FINISH				<p>SEC561X/571X WIRING DIAGRAM</p>
USED ON	SEC561X/571X	APPLICATION		DO NOT SCALE DRAWING	SEE A	<p>DWG. NO. FIGURE 6</p> <p>SCALE:1:1 WEIGHT: SHEET 1 OF 1</p>

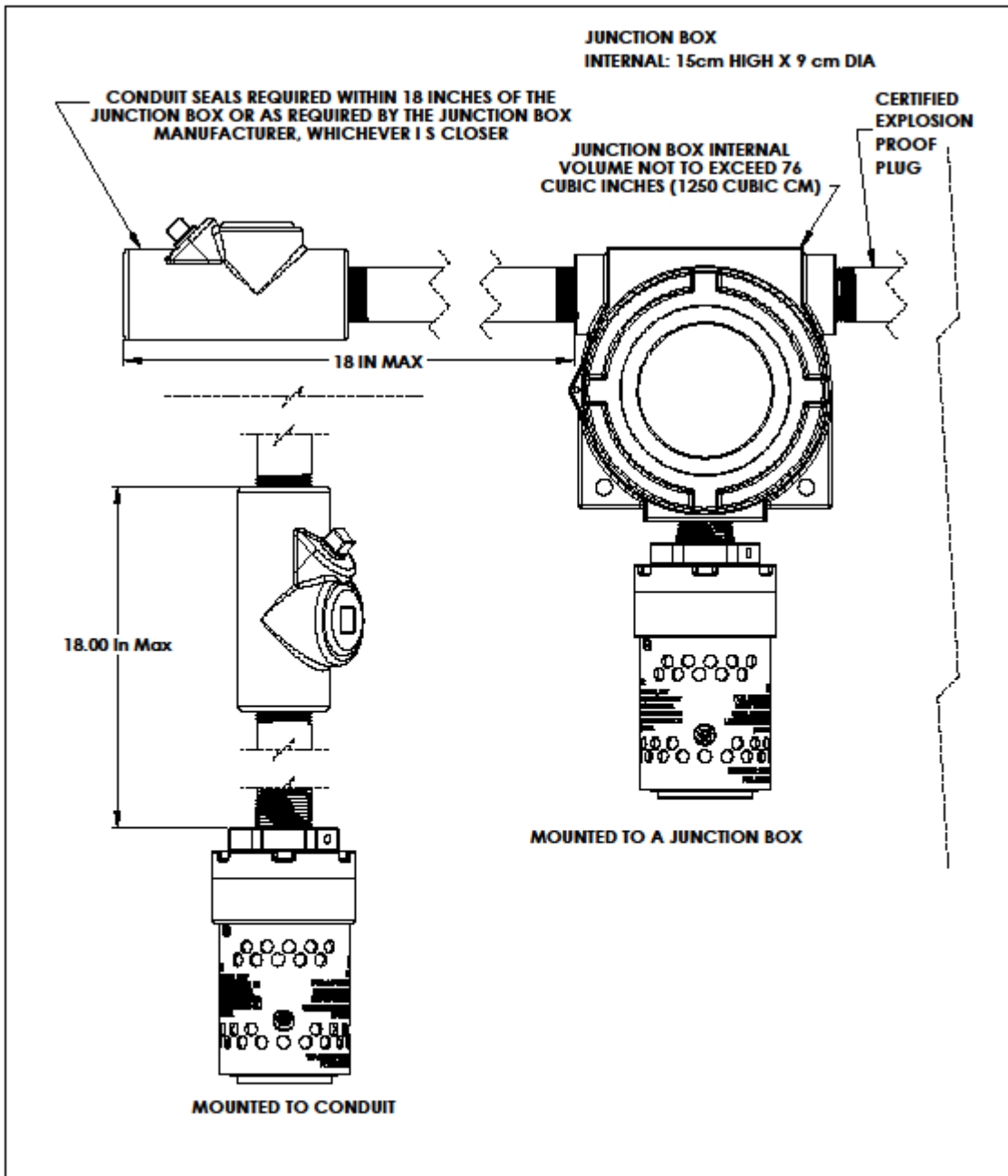

APPROVALS:	DIMENSIONS ARE IN INCHES TOLERANCES: FRACTIONAL: MACH ± ANGULAR: MACH ± BEND ± TWO PLACE DECIMAL ±.010 THREE PLACE DECIMAL ±.005	NAME	DATE	<p>Sensor Electronics Corp. 12730 Creek View Ave Savage, Minnesota 55378</p>
SCHEMATIC		DRAWN		
PWB RAW		CHECKED		
CERT DWG	MATERIAL	MFG APPL.		<p>SENSOR ELECTRONICS</p> <p>SAMPLE INSTALLATION ILLUSTRATION</p>
NEXT ASSY	FINISH	<p>PROPRIETARY AND CONFIDENTIAL</p> <p>THE INFORMATION CONTAINED IN THIS DRAWING IS THE SOLE PROPERTY OF SENSOR ELECTRONICS CORP. ANY REPRODUCTION IN PART OR AS A WHOLE WITHOUT THE WRITTEN PERMISSION OF SENSOR ELECTRONICS CORP. IS PROHIBITED.</p>		
USED ON	DO NOT SCALE DRAWING	SIZE	DWG. NO.	REV. NA
APPLICATION		A	NOT ASSIGNED	SCALE: 1:1